



KIESELMANN
FLUID PROCESS GROUP

Operating instructions

- Translation of the original -

**Single seat valve
Two-way-valve
Type: 5714**

pneumatic operation



1. List of contents

1.	List of contents	2
2.	Information for your safety.....	3
3.	Marking of security instructions in the operating manual	3
4.	Safety instructions	4
4.1	Field of application	4
4.2	General safety instructions	4
4.3	General notes	4
5.	Function.....	4
5.1	Functional description	4
6.	Installation informations.....	5
6.1	Installations instructions.....	5
6.2	Welding guidelines.....	5
7.	Maintenance.....	5
7.1	Maintenance	5
7.2	Cleaning.....	5
8.	Control system - and interrogation system.....	5
8.1	Control head - optional-	5
8.2	Proximity switch mounting set -optional-.....	5
9.	Technical data	6
10.	Pneumatic valve actuation	7
10.1	Actuator: air open - spring close	7
10.2	Actuator: air close - spring open	7
10.3	Actuator: air open - air close	7
11.	Disassembly and assembly	8
11.1	Removing the pneum. valve insert (air open/spring close)	8
11.2	Removing the pneum. valve insert (air close/spring open) (air open/air close)	8
11.3	Disassembly.....	8
11.4	Assembly	8
12.	Dimensions.....	9
12.1	Size measurement table	9
12.2	Dimensioned drawing	9
13.	Drawings	10
13.1	air open - spring close.....	10
13.2	air close - spring open.....	11
13.3	air open - air close	12
14.	Manufacturing.....	13
14.1	Structure of Article number	13
15.	Spare parts list	15
16.	Two-way-valve Type: 5714 (1.4404 / AISI316L)	15
16.1	Valve insert VE	15
16.2	Seal kit EPDM	16
16.3	Seal kit HNBR	16
17.	Declaration of incorporation	17

2. Information for your safety

We are pleased that you have decided for a high-class KIESELMANN product. With correct application and adequate maintenance, our products provide long time and reliable operation.



Before installation and initiation, please carefully read this instruction manual and the security advices contained in it. This guarantees reliable and safe operation of this product and your plant respectively. Please note that an incorrect application of the process components may lead to great material damages and personal injury.

In case of damages caused by non observance of this instruction manual, incorrect initiation, handling or external interference, guarantee and warranty will lapse!

Our products are produced, mounted and tested with high diligence. However, if there is still a reason for complaint, we will naturally try to give you entire satisfaction within the scope of our warranty. We will be at your disposal also after expiration of the warranty. In addition, you will also find all necessary instructions and spare part data for maintenance in this instruction manual. If you don't want to carry out the maintenance by yourself, our KIESELMANN service team will naturally be at your disposal.

3. Marking of security instructions in the operating manual

Hints are available in the chapter "safety instructions" or directly before the respective operation instruction. The hints are highlighted with a danger symbol and a signal word. Texts beside these symbols have to be read and adhered to by all means. Please continue with the text and with the handling at the valve only afterwards.

Symbol	Signal word	Meaning
	DANGER	Imminent danger which may cause severe personal injury or death.
	ATTENTION	Dangerous situation which may cause slight personal injury or material damages.
	NOTE	Marks application hints and other information which is particularly useful.

4. Safety instructions

4.1 Field of application

Two-way-valves are utilised as a multiple valve in food and beverage as well as in pharmaceutical, biotechnological and chemical industries.



ATTENTION

- To avoid danger and damage, the fitting must be used in accordance with the safety instructions and technical data contained in the operating instructions.

4.2 General safety instructions



DANGER

- Danger of crushing or amputating limbs.
Do not reach into the valve housing when in pneumatic mode.
- Dismantling the valve or valve assemblies from the plant can cause injuries from fluids or gases flowing out.
Dismantle the valve or valve assembly only when the plant has been rendered pressure-less and free of liquid and gas.
- The spring preloaded valve insert (air open - spring close) may incur serious injuries by jumping out of the housing.
Pneumatically open the valve before disassembling the clamp coupling, so that upstroke the piston in direction "X" (Fig. 5 /Page 10).



ATTENTION

- To avoid air leaking, only use pneumatic connection parts that have an o-ring seal facing the even surface.
- When mounting the clamps, the max. torque must not be exceeded (see technical data).
- Steps should be taken to ensure that no external forces are exerted on the fitting.

4.3 General notes



NOTE

- All data are in line with the current state of development. Subject to change as a result of technical progress.

5. Function

5.1 Functional description

- Function of valve: To guide liquid media optionally from one pipe to two pipelines separated from each other and vice versa.(see Fig.1 and 2)
- Operation: Pneumatic lift drive and moved by spring force.
- Activation: 3/2-way solenoid valve.

Valve position A-D open
connection (U) closed

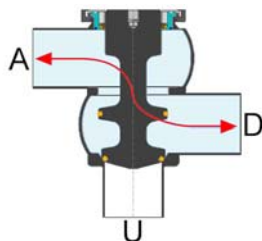

Fig. 1

Valve position D-U open
connection (A) closed

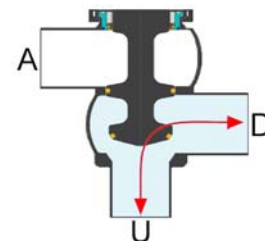

Fig. 2

6. Installation informations

6.1 Installations instructions

Preferably install the two way change-over valve vertically. Install the connection lines in such a way as to permit the liquids to drain freely out of the housing.



NOTE

If installed horizontally, some minor residual liquids will remain in the ball-shape of the housing.

Valves with welded ends that serve as connecting members can be directly welded to the piping.

6.2 Welding guidelines

Sealing elements integrated in weld components must generally be removed prior to welding.

To prevent damage, welding should be undertaken by certified personnel (EN287). Use the TIG (Tungsten Inert Gas) welding process.



NOTE

Impurities can cause damage to the seals and seals area. Clean inside areas prior to assembly.

7. Maintenance

7.1 Maintenance

The maintenance intervals depend on the operating conditions "temperature, temperature-intervals, medium, cleaning medium, pressure and opening frequency". It is recommended to change the leakage butterfly valve-seal annually. The maintenance intervals, however, depend on the condition of the seals and are to be fixed by the user.

► Actuator

The actuator is maintenance-free and non-removable.



NOTE

Seal materials

EPDM; Viton; k-flex

NBR; HNBR; Silicone

Thread

→

→

→

Lubricants

Klüber Paraliq GTE*

Klüber Paraliq GB 363*

Teflon grease Interflon*

*) It is only permitted to use approved lubricants, if the respective fitting is used for the production of food or drink. Please observe the relevant safety data sheets of the manufacturers of lubricants.

7.2 Cleaning

Cleaning of the upper and lower valve chambers is performed with the pipe cleaning system.

8. Control system - and interrogation system

8.1 Control head - optional-

Optionally, modular valve control systems can be installed to the actuator for reading and actuating valve positions. The standard version is a closed system with twofold limit position messaging (standard), with SPS, Interbus or ASI bus switch-on electronics, and integrated 3/2-way solenoid valves. For tough operating conditions we recommend employing a stainless steel hood.

8.2 Proximity switch mounting set -optional-

For the acquisition of the valve positions over inductive initiators, a limit switch support is mounted on the actuation. The enquiry takes place over the position of the piston rod.

9. Technical data

Model:	Two-way-valve pneumatic operation	
Valve size:	NW 25 - 100	
Connections:	Welding end DIN11850 S2	
Temperature range:	<ul style="list-style-type: none"> Ambient temperature: +4° to +45°C Product temperature: +0° to +95°C medium dependent Sterilization temperature: <ul style="list-style-type: none"> EPDM +140°C short-time (30 min.) HNBR +130°C short-time (30 min.) 	
Vaccum:	1,5 - 10 ⁻⁶ mbar x 1/5 (test pressure 0,5mbar)	
Control air pressure:	6,0 - 8,0 bar	
Quality of control air:	ISO 8573-1 : 2001 quality class 3	
Material:	in product contact	not in product contact
Stainless steel type:	1.4404 / AISI316L	1.4301 / AISI304 1.4305 / AISI303
Surfaces:	RA ≤0,8µm e-pol.	metallic bright, e-pol.
Seals:	EPDM (FDA) HNBR (FDA)	HNBR

Operations pressures (bar): (6bar Control air pressure)

Fig.1 Connection (U)

air open-spring close
air close - spring open
air open-air close

Connection (A-D)

air open-spring close
air close - spring open
air open-air close

Fig.2 Connection (A)

air open-spring close
air close - spring open
air open-air close

Connection (D-U)

air open-spring close
air close - spring open
air open-air close

Tightening moment: Torque in Nm

Fluiddynamic measurement : (accroding to DIN EN 60534-2-3)

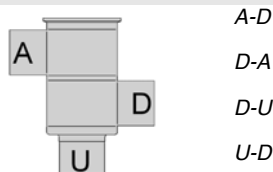

* no value available

Nennweite DN

DIN INCH	25	40	50	65	80	100
	1	1½	2	2½	3	4

10	10	10	6	10	7
10	10	10	7,5	10	7,5
10	10	10	10	10	10

9	9	9	6	10	6
5	5	5	3	5	3
10	10	10	8	10	8

1,5	1,5	1,5	1	2	1,3
5	5	5	3	5	3
10	10	10	10	10	10

9	9	9	6	10	6
9	9	9	6	9,5	6
10	10	10	8	10	8

Clamp coupling: Nominal width NW

DIN INCH	25	40	50	65	80	100
	1	1½	2	2½	3	4
	15	15	15	25	20	55

Nominal width NW

DIN INCH	25	40	50	65	80	100
	1	1½	2	2½	3	4
	12	35	65	101	153	170
	12	35	65	101	153	180
	23	46	84	138	220	270
	25	48	82	140	220	270

10. Pneumatic valve actuation

10.1 Actuator: air open - spring close

Valve function	pneumatic control with MV in control unit (Fig. 3 /Page 7)	pneumatic control with external solenoid valve (MV) (Fig. 3 /Page 7)
Valve "OPEN"	control air feed P → MV1 → P1/LA2 Valve is opening by control air	control air feed ext. MV → LA2 Valve is opening by control air
Valve "CLOSED"	de-aeration LA2/P1 → MV1 → R Valve is closing by spring	de-aeration LA → ext. MV Valve is closing by spring

10.2 Actuator: air close - spring open

Valve function	pneumatic control with MV in control unit (Fig. 3 /Page 7)	pneumatic control with external solenoid valve (MV) (Fig. 3 /Page 7)
Valve "CLOSED"	control air feed P → MV1 → P1/LA1 Valve is closing by control air	control air feed ext. MV → LA1 Valve is closing by control air
Valve "OPEN"	de-aeration P1/LA1 → MV1 → R Valve is opening by spring	de-aeration LA1 → ext. MV Valve is opening by spring

10.3 Actuator: air open - air close

Valve function	pneumatic control with MV in control unit (Fig. 3 /Page 7)	pneumatic control with external solenoid valve (MV) (Fig. 3 /Page 7)
Valve "OPEN"	control air feed P → MV1 → P1/LA1 Valve is opening by control air	control air feed ext. MV → LA1 Valve is opening by control air
Valve "CLOSED"	de-aeration P → MV3 → P3/LA2 Valve is closing by control air	de-aeration ext. MV → LA2 Valve is closing by control air

MV = solenoid valve
R = de-aeration, sound absorber
P = compressed-air inlet (control unit)
LA = compressed air inlet (actuation)
S = slide switch - manual control (solenoid valves)

I = initiatoren
H = angle bracket
E = de-aeration
LA = air connection

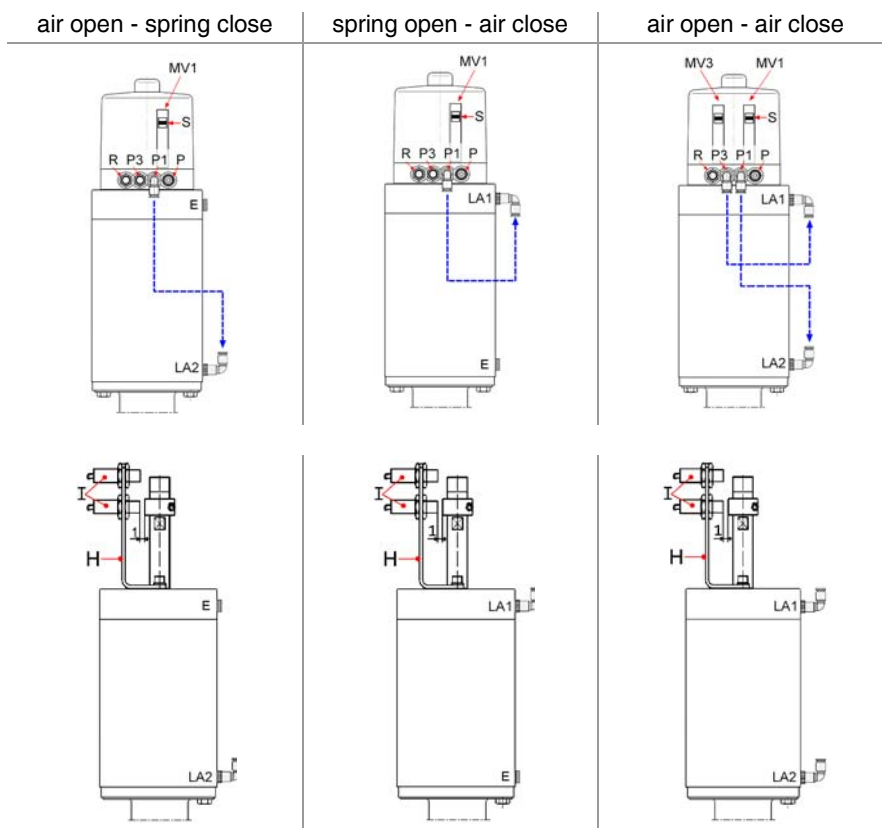

Fig. 3

11. Disassembly and assembly

➤ Lubricants

• EPDM; Viton; k-flex
Klüber Paraliq GTE 703

• NBR; HNBR; Silicone
Klüber Paraliq GB 363

• Thread
Teflongrease Interflon

11.1 Removing the pneum. valve insert (air open/spring close)

- Pneumatically open the valve, so that upstroke the piston (1) in direction X (Fig. 5 /Page 10).
- Remove clamp coupling (3).
- In an upward direction, dismount the complete valve insert from the valve.

11.2 Removing the pneum. valve insert (air close/spring open) (air open/air close)

- Remove clamp coupling (3).
- In an upward direction, dismount the complete valve insert from the valve.

11.3 Disassembly



NOTE

All threaded joint have right-hand thread.

Unscrew and remove control air, steam i.e. cleaning lines and electrical lines, complete proximity switch mounting or control head.

➤ Exchanging „A“ Item. (D1), (D2), (D3), (D4).

- Loosen screw (7) and move the lantern (6) until the spanner flat (SW1) and the borehole (B1) is visible.
- Unscrew piston (1) from piston rod (8) (SW1/B1).
- Slide off insert (2) with bearing bush (4), Seal (D3) and O-ring (D4) in opposite direction to the valve side of the piston's "X".
- Replace seals and wearing parts.



NOTE

Puncture the o-ring (D1) and (D2) at the centre with a pointed tool and remove them carefully from the groove.

➤ Exchanging „B“ Item. (D5).

- See - Dismantling exchanging seals „A“.
- Remove screw (7) and dismount the lantern (6).
- Screw off the thread connection Pos. (G1) of the piston rods (8) and the spindle (11) at the spanner surfaces (SW1 und SW2).
- Remove axially the piston rod (8) and shaft (10) with spindle (11) from the lift drive.
- Replace the o-ring (D5) (2x).

11.4 Assembly

- Thoroughly clean and slightly lubricate mounting areas and running surfaces.
- Assemble in reverse order.



NOTE

Alternately press and roll the seal (D1) and (D2) into the groove with round body.

- Thread connection (G1) assembly with **removeable screw retention (e.g. Loctite 243)** .
- Assemble in reverse order.
- Check the valve function.

12. Dimensions

12.1 Size measurement table

DN	d1	d3	L1	L2	L3
25 1 INCH	26 22,1	29 25,4	75	36	401
40 1½ INCH	38 34,8	41 38,1	85	48	405
50 2 INCH	50 47,5	53 50,8	85	60	409
65 2½ INCH	66 60,2	70 63,5	105	76	430
80 3 INCH	81 72,8	85 76,1	115	91	531
100 4 INCH	100 97,4	104 101,6	130	110	559

12.2 Dimensioned drawing

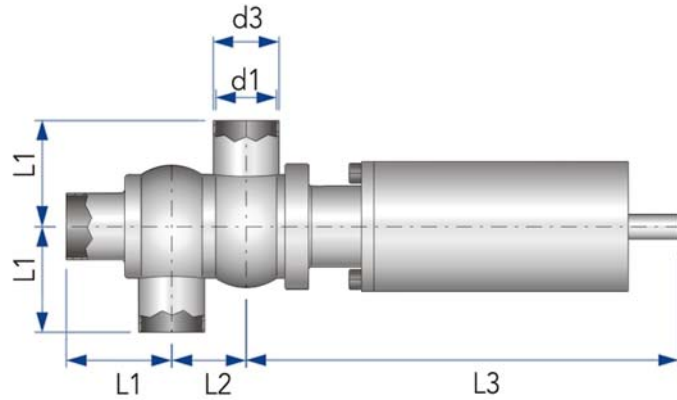

Fig. 4

13. Drawings

13.1 air open - spring close

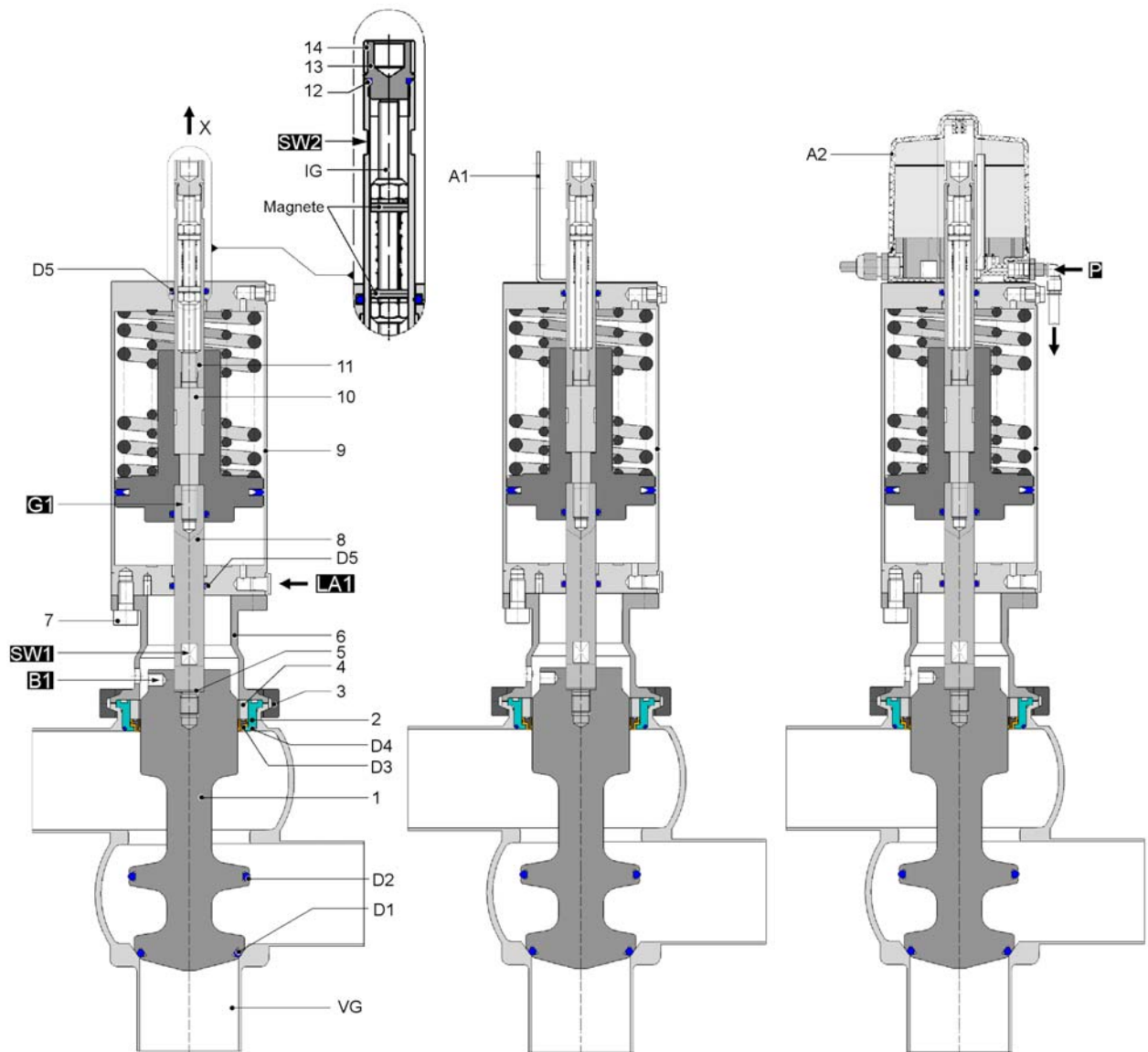

Fig. 5

- 1) Piston
- 2) Insert
- 3) Clamp coupling
- 4) Bearing bush
- 5) Washer screw retention
- 6) Lantern
- 7) Screw
- 8) Piston rod
- 9) Actuator

- 10) Shaft
- 11) Spindle upper
- 12) O-Ring
- 13) Position indication
- 14) Cap

- D1) O-Ring
- D2) O-Ring
- D3) Seal
- D4) O-Ring
- D5) O-Ring

- VG) Housing
- IG) Pulse generator
- A1) Proximity switch mounting
- A2) Control head

13.2 air close - spring open

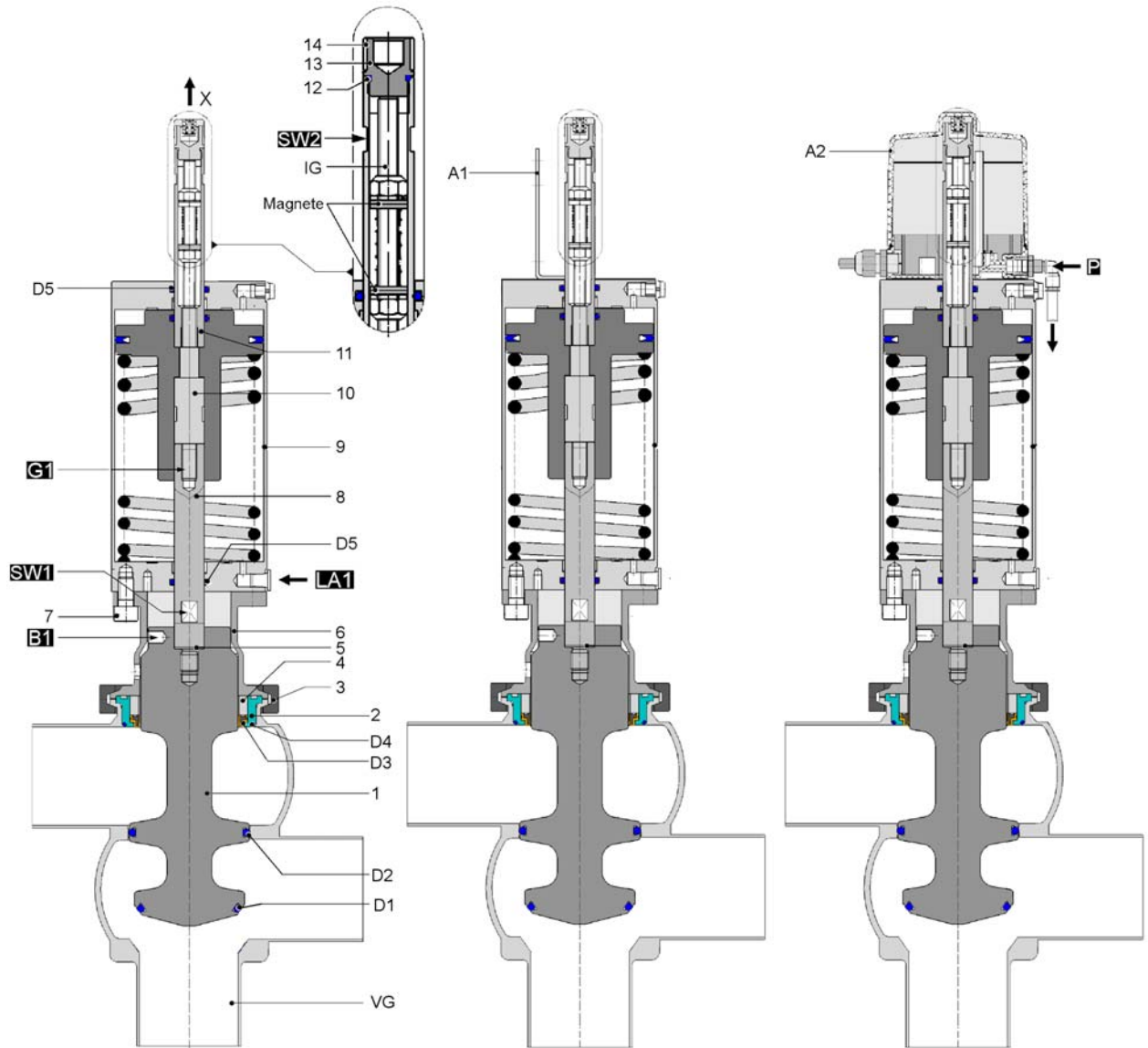

Fig. 6

- 1) Piston
- 2) Insert
- 3) Clamp coupling
- 4) Bearing bush
- 5) Washer screw retention
- 6) Lantern
- 7) Screw
- 8) Piston rod
- 9) Actuator

- 10) Shaft
- 11) Spindle upper
- 12) O-Ring
- 13) Position indication
- 14) Cap

- D1) O-Ring
- D2) O-Ring
- D3) Seal
- D4) O-Ring
- D5) O-Ring
- VG) Housing
- IG) Pulse generator
- A1) Proximity switch mounting
- A2) Control head

13.3 air open - air close

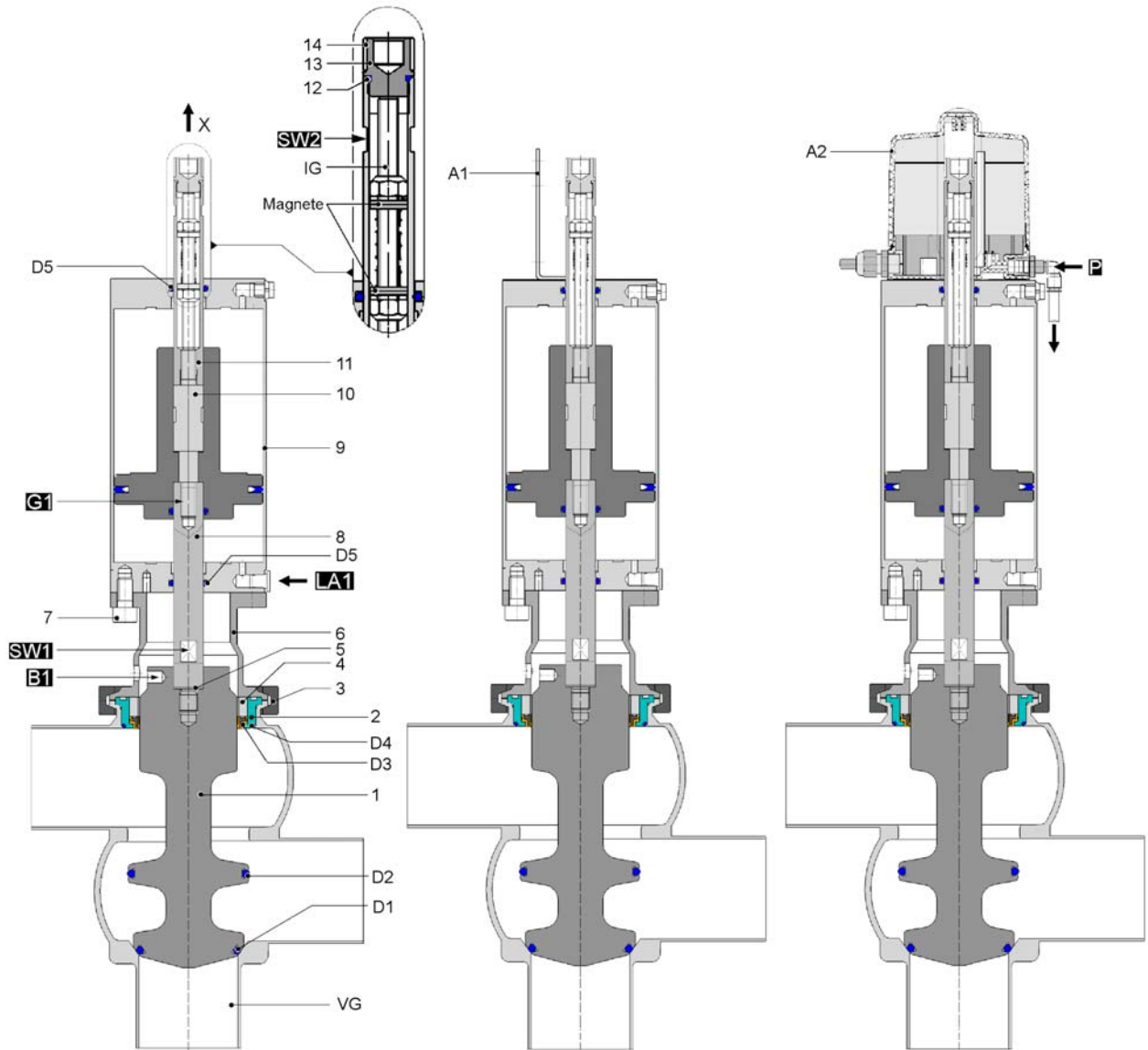

Fig. 7

- 1) Piston
- 2) Insert
- 3) Clamp coupling
- 4) Bearing bush
- 5) Washer screw retention
- 6) Lantern
- 7) Screw
- 8) Piston rod
- 9) Actuator

- 10) Shaft
- 11) Spindle upper
- 12) O-Ring
- 13) Position indication
- 14) Cap

- D1) O-Ring
- D2) O-Ring
- D3) Seal
- D4) O-Ring
- D5) O-Ring
- VG) Housing
- IG) Pulse generator
- A1) Proximity switch mounting
- A2) Control head

14. Manufacturing

14.1 Structure of Article number

5714 050 030 - 041

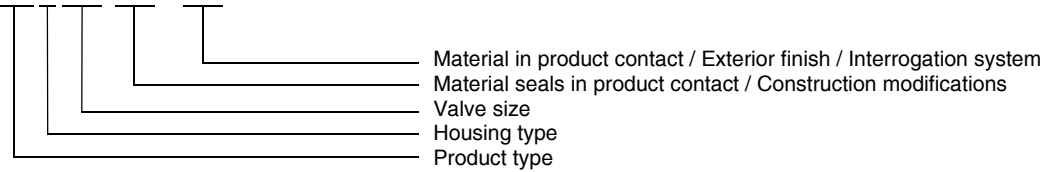

➤ Product type

57xx = Single seat valve

➤ Housing type

Two-way valve

S-S-S

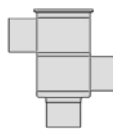

➤ Valve size

DN = Nominal diameter

DIN	025 = DN25	040 = DN50	050 = DN50	065 = DN65	080 = DN80	100 = DN100	125 = DN125	150 = DN150
Zoll	026 = DN1	038 = DN1½	051 = DN2	064 = DN2½	076 = DN3	101 = DN4	-	-

➤ Material seal / Construction modifications

Material seals in product contact:

- EPDM

- HNBR

Construction modifications:

Type of actuation - air open - spring close

- air open - air close

- spring open - air close

➤ Material in product contact / Exterior finish

020 - 1.4301/1.4307 AISI304/307 - bright turned

040 - 1.4301/1.4307 AISI304/307 - bright turned

021 - 1.4301/1.4307 AISI304/307 - E-polished

041 - 1.4301/1.4307 AISI304/307 - E-polished

022 - 1.4301/1.4307 AISI304/307 - unpolished, glass-bead blasted

042 - 1.4301/1.4307 AISI304/307 - unpolished, glass-bead blasted

➤ Interrogation system

Article number	Control System or Interrogation System (A1, A2)					Pulse generator IG	
57xx DN xxx	-041	-	-----	-	-	Valve without Control- or Interrogation System	-----
57xx DN xxx	-750	Mounting	5630 005 000-020	-	-	Valve with Sensor mounting set	-----

Control head ASI-Bus for Single seat valve

57xx DN xxx	-600	Control head	5630 500 000-000	ASI-Bus Standard	0 MV	ASI 2-wire cable adapter	5702 DN 005-000
57xx DN xxx	-601	Control head	5630 501 000-000	ASI-Bus Standard	1 MV	ASI 2-wire cable adapter	5702 DN 005-000
57xx DN xxx	-602	Control head	5630 502 000-000	ASI-Bus Standard	2 MV	ASI 2-wire cable adapter	5702 DN 005-000
57xx DN xxx	-603	Control head	5630 503 000-000	ASI-Bus Standard	3 MV	ASI 2-wire cable adapter	5702 DN 005-000
57xx DN xxx	-604	Control head	5630 503 010-000	ASI-Bus/ES/ABSL	3 MV	Plug M12 4-pin / plug socket M12 5-pin	5702 DN 005-000
57xx DN xxx	-605	Control head	5630 503 051-000	ASI-Bus/ABSL	3 MV	Plug M12 4-pin, ES-LA	5702 DN 005-000
57xx DN xxx	-606	Control head	5630 501 010-000	ASI-Bus/ES/ABSL	1 MV	Plug M12 4-pin / plug socket M12 5-pin	5702 DN 005-000
57xx DN xxx	-607	Control head	5630 501 051-000	ASI-Bus/ABSL	1 MV	Stecker M12 4-pin, ES-LA	5702 DN 005-000
57xx DN xxx	-609	Control head	5630 503 050-000	ASI-Bus/ABSL	3 MV	Plug M12 4-pin	5702 DN 005-000
57xx DN xxx	-610	Control head	5630 502 010-000	ASI-Bus/ES/ABSL	2 MV	Plug M12 4-pin / plug socket M12 5-pin	5702 DN 005-000
57xx DN xxx	-613	Control head	5630 502 051-000	ASI-Bus/ABSL	2 MV	Plug M12 4-pin, ES-LA	5702 DN 005-000
57xx DN xxx	-614	Control head	5630 503 053-000	ASI-Bus/ABSL	3 MV	ASI 2-wire cable adapter	5702 DN 005-000
57xx DN xxx	-615	Control head	5630 503 003-000	ASI-Bus Standard	3 MV	KV M16x1,5 / Pg 9	5702 DN 005-000
57xx DN xxx	-616	Control head	5630 501 003-000	ASI-Bus Standard	1 MV	KV M16x1,5 / Pg 9	5702 DN 005-000
57xx DN xxx	-619	Control head	5630 503 151-000	ASI-Bus/ABSL	3 MV	Plug M12 4-pin, LED-ESH	5702 DN 005-000
57xx DN xxx	-620	Control head	5630 501 050-000	ASI-Bus/ABSL	1 MV	Plug M12 4-pin	5702 DN 005-000
57xx DN xxx	-624	Control head	5630 502 050-000	ASI-Bus/ABSL	2 MV	Plug M12 4-pin	5702 DN 005-000
57xx DN xxx	-625	Control head	5630 501 158-000	ASI-Bus/ABSL	1 MV	KV M16x1,5, LED-ESH	5702 DN 005-000
57xx DN xxx	-626	Control head	5630 502 158-000	ASI-Bus/ABSL	2 MV	KV M16x1,5, LED-ESH	5702 DN 005-000
57xx DN xxx	-627	Control head	5630 503 158-000	ASI-Bus/ABSL	3 MV	KV M16x1,5, LED-ESH	5702 DN 005-000
57xx DN xxx	-628	Control head	5630 501 151-000	ASI-Bus/ABSL	1 MV	Plug M12 4-pin, LED-ESH	5702 DN 005-000
57xx DN xxx	-629	Control head	5630 501 151-000	ASI-Bus/ABSL	1 MV	Plug M12 4-pin, LED-ESH, ES-LA	5702 DN 005-000
57xx DN xxx	-630	Control head	5630 500 061-000	ASI-Bus Standard	0 MV	Plug M12 4-pin	5702 DN 005-000
57xx DN xxx	-631	Control head	5630 501 061-000	ASI-Bus Standard	1 MV	Plug M12 4-pin	5702 DN 005-000
57xx DN xxx	-632	Control head	5630 502 061-000	ASI-Bus Standard	2 MV	Plug M12 4-pin	5702 DN 005-000
57xx DN xxx	-633	Control head	5630 503 061-000	ASI-Bus Standard	3 MV	Plug M12 4-pin	5702 DN 005-000
57xx DN xxx	-640	Control head	5630 501 058-000	ASI-Bus/ABSL	1 MV	KV 2x M16x1,5	5702 DN 005-000
57xx DN xxx	-641	Control head	5630 502 058-000	ASI-Bus/ABSL	2 MV	KV 2x M16x1,5	5702 DN 005-000
57xx DN xxx	-642	Control head	5630 503 058-000	ASI-Bus/ABSL	3 MV	KV 2x M16x1,5	5702 DN 005-000

Control head SPS for Single seat valve

57xx DN xxx	-500	Control head	5630 300 000-000	SPS-Standard	0 MV	KV M16x1,5 / Pg 9	5702 DN 005-000
57xx DN xxx	-501	Control head	5630 301 000-000	SPS-Standard	1 MV	KV M16x1,5 / Pg 9	5702 DN 005-000
57xx DN xxx	-502	Control head	5630 302 000-000	SPS-Standard	2 MV	KV M16x1,5 / Pg 9	5702 DN 005-000
57xx DN xxx	-503	Control head	5630 303 000-000	SPS-Standard	3 MV	KV M16x1,5 / Pg 9	5702 DN 005-000
57xx DN xxx	-504	Control head	5630 321 000-000	SPS-Standard	1 MV	Plug M12 7-polig	5702 DN 005-000
57xx DN xxx	-505	Control head	5630 301 108-000	SPS-Standard	1 MV	KV 2x M16x1,5 / Pg 9, LED-ESH	5702 DN 005-000
57xx DN xxx	-506	Control head	5630 302 108-000	SPS-Standard	2 MV	KV 2x M16x1,5 / Pg 9, LED-ESH	5702 DN 005-000
57xx DN xxx	-507	Control head	5630 303 108-000	SPS-Standard	3 MV	KV 2x M16x1,5 / Pg 9, LED-ESH	5702 DN 005-000
57xx DN xxx	-508	Control head	5630 301 100-000	SPS-Standard	1 MV	KV M16x1,5 / Pg 9, ESH	5702 DN 005-000
57xx DN xxx	-510	Control head	5630 X00 040-000	SPS-Standard	0 MV	KV M16x1,5 / Pg 9, Valve tag	5702 DN 005-000
57xx DN xxx	-513	Control head	5630 303 040-000	SPS-Standard	3 MV	KV M16x1,5 / Pg 9, Valve tag	5702 DN 005-000

DN - Nominal diameter z.B. 5714 050 030-041
 MV - Solenoid valve
 KV - Compression gland 4,5-6mm
 ESH - Stainless steel cap
 ES-LA - Air connection (steel stainless)

15. Spare parts list

16. Two-way-valve Type: 5714 (1.4404 / AISI316L)

Seal	Actuator	Article-NO.	Valve insert VE	Housing VG	Seal kit
EPDM	lö - fs	5714 DN 030-xxx	5714 DN 020-041	5713 DN 031-041	5714 DN 990-054
	fö - ls	5714 DN 130-xxx	5714 DN 023-041	5713 DN 031-041	5714 DN 990-054
	lö - ls	5714 DN 330-xxx	5714 DN 026-041	5713 DN 031-041	5714 DN 990-054
HNBR	lö - fs	5714 DN 035-xxx	5714 DN 021-041	5713 DN 031-041	5714 DN 990-050
	fö - ls	5714 DN 135-xxx	5714 DN 024-041	5713 DN 031-041	5714 DN 990-050
	lö - ls	5714 DN 335-xxx	5714 DN 027-041	5713 DN 031-041	5714 DN 990-050

DN = Nominal diameter e.g. 5673 050 130-041 = DN50, 5673 051 130-041 = 2INCH

xxx = Interrogation system

lö = air open

ls = air close

fö = spring open

fs = spring close

16.1 Valve insert VE

Item	Designation	Material	DN25 1 INCH	DN40 1½ INCH	DN50 2 INCH	DN65 2½ INCH	DN80 3 INCH	DN100 4 INCH
VE	Valve insert lö - fs - DIN -INCH	EPDM	5714 025 020-041	5714 040 020-041	5714 050 020-041	5714 065 020-041	5714 080 020-041	5714 100 020-041
	Valve insert fö - ls - DIN -INCH		5714 026 020-041	5714 038 020-041	5714 051 020-041	5714 064 020-041	5714 076 020-041	5714 101 020-041
	Valve insert lö - ls - DIN -INCH		5714 025 023-041	5714 040 023-041	5714 050 023-041	5714 065 023-041	5714 080 023-041	5714 100 023-041
VE	Valve insert lö - fs - DIN -INCH	HNBR	5714 026 023-041	5714 038 023-041	5714 051 023-041	5714 064 023-041	5714 076 023-041	5714 101 023-041
	Valve insert fö - ls - DIN -INCH		5714 025 026-041	5714 040 026-041	5714 050 026-041	5714 065 026-041	5714 080 026-041	5714 100 026-041
	Valve insert lö - ls - DIN -INCH		5714 026 026-041	5714 038 026-041	5714 051 026-041	5714 064 026-041	5714 076 026-041	5714 101 026-041
1	Piston -DIN -INCH	AISI316L	5714 025 021-041	5714 040 021-041	5714 050 021-041	5714 065 021-041	5714 080 021-041	5714 100 021-041
			5714 026 021-041	5714 038 021-041	5714 051 021-041	5714 064 021-041	5714 076 021-041	5714 101 021-041
			5714 025 024-041	5714 040 024-041	5714 050 024-041	5714 065 024-041	5714 080 024-041	5714 100 024-041
2	Insert	AISI316L	5714 026 024-041	5714 038 024-041	5714 051 024-041	5714 064 024-041	5714 076 024-041	5714 101 024-041
			5714 025 027-041	5714 040 027-041	5714 050 027-041	5714 065 027-041	5714 080 027-041	5714 100 027-041
			5714 026 027-041	5714 038 027-041	5714 051 027-041	5714 064 027-041	5714 076 027-041	5714 101 027-041
3	Clamp coupling	AISI316L	5714 025 002-040	5714 040 002-040	5714 050 002-040	5714 065 002-040	5714 080 002-040	5714 100 002-040
			5714 026 002-040	5714 038 002-040	5714 051 002-040	5714 064 002-040	5714 076 002-040	5714 101 002-040
4	Bearing bush	AISI316L	5622 050 005-040	5622 050 005-040	5622 050 005-040	5622 065 005-040	5622 080 005-040	5713 100 003-040
			2122 065 100-020	2122 065 100-020	2122 065 100-020	2122 080 100-020	2122 115 100-020	2122125100-020
5	Washer screw retention	AISI304	5622 050 006-053	5622 050 006-053	5622 050 006-053	5622 065 006-053	5622 080 006-053	5622100006-053
			8135 012 195-040	8135 012 195-040	8135 012 195-040	8135 012 195-040	8135 012 195-040	8135012195-040
6	Lantern	AISI304	5706 050 010-021	5706 050 010-021	5706 050 010-021	5706 065 008-021	5706 080 008-021	5706100008-021
			8095 010 020-020	8095 010 020-020	8095 010 020-020	8095 010 020-020	8106 008 016-020	8106 008 016-020
7	Screw	AISI316L	M10x20 (2x)	M10x20 (2x)	M10x20 (2x)	M10x20 (2x)	M8x16 (4x)	M8x16 (4x)
			5200 104 052-020	5200 104 052-020	5200 104 052-020	5200 104 052-020	5200 157 057-020	5200 157 057-020
8	Piston rod	AISI304	5200 104 051-032	5200 104 051-032	5200 104 051-032	5200 104 051-032	5200 157 051-032	5200 157 051-032
			5400 104 051-032	5400 104 051-032	5400 104 051-032	5400 104 051-032	5400 157 051-032	5400 157 051-032
			5300 104 050-032	5300 104 050-032	5300 104 050-032	5300 104 050-032	5300 157 051-032	5300 157 051-032
9	Actuator lö - fs Actuator fö - ls Actuator lö - ls	AISI304 AISI304 AISI304	5200 104 053-020	5200 104 053-020	5200 104 053-020	5200 104 053-020	5200 157 056-020	5200 157 056-020
			5622 100 070-220	5622 100 070-220	5622 100 070-220	5622 100 070-220	5622 100 070-220	5622 100 070-220
10	Shaft	AISI304	5200 104 051-032	5200 104 051-032	5200 104 051-032	5200 104 051-032	5200 157 051-032	5200 157 051-032
			5400 104 051-032	5400 104 051-032	5400 104 051-032	5400 104 051-032	5400 157 051-032	5400 157 051-032
11	Spindle upper	AISI303	5300 104 050-032	5300 104 050-032	5300 104 050-032	5300 104 050-032	5300 157 051-032	5300 157 051-032
			5200 104 053-020	5200 104 053-020	5200 104 053-020	5200 104 053-020	5200 157 056-020	5200 157 056-020
12	O-Ring	EPDM	5622 100 070-220	5622 100 070-220	5622 100 070-220	5622 100 070-220	5622 100 070-220	5622 100 070-220
			2304 012 020-055	2304 012 020-055	2304 012 020-055	2304 012 020-055	2304 012 020-055	2304 012 020-055
13	Position indication	ABS gn	5622 100 058-152	5622 100 058-152	5622 100 058-152	5622 100 058-152	5622 100 058-152	5622 100 058-152
			5622 100 071-220	5622 100 071-220	5622 100 071-220	5622 100 071-220	5622 100 071-220	5622 100 071-220
14	Cap	AISI303	5622 100 058-152	5622 100 058-152	5622 100 058-152	5622 100 058-152	5622 100 058-152	5622 100 058-152
			5622 100 071-220	5622 100 071-220	5622 100 071-220	5622 100 071-220	5622 100 071-220	5622 100 071-220

16.2 Seal kit EPDM

Item	Designation	Material	DN25 1 INCH	DN40 1½ INCH	DN50 2 INCH	DN65 2½ INCH	DN80 3 INCH	DN100 4 INCH
	Seal kit	EPDM	5714 025 990-054	5714 040 990-054	5714 050 990-054	5714 065 990-054	5714 080 990-054	5714 100 990-054
D1	O-Ring	EPDM	2304 041 035-159	2304 044 053-159	2304 044 053-159	2304 053 053-159	2304 069 053-159	2304 088 053-159
D2	O-Ring	EPDM	2304 053 053-159	2304 053 053-159	2304 053 053-159	2304 069 053-159	2304 088 053-159	2304 113 053-084
D3	Seal	EPDM	5622 050 010-069	5622 050 010-069	5622 050 010-069	5622 065 010-069	5622 080 010-069	5622 100 010-069
D4	O-Ring	EPDM	2304 069 026-159	2304 069 026-159	2304 069 026-159	2304 082 026-159	2304 098 035-159	2304 118 045-055
D5	O-Rings (2x)	HNBR	2304 019 035-171	2304 019 035-171	2304 019 035-171	2304 019 035-171	2304 019 035-171	2304 019 035-171

16.3 Seal kit HNBR

Item	Designation	Material	DN25 1 INCH	DN40 1½ INCH	DN50 2 INCH	DN65 2½ INCH	DN80 3 INCH	DN100 4 INCH
	Seal kit	HNBR	5714 025 990-050	5714 040 990-050	5714 050 990-050	5714 065 990-050	5714 080 990-050	5714 100 990-050
D1	O-Ring	HNBR	2304 041 035-050	2304 044 053-157	2304 044 053-157	2304 053 053-157	2304 069 053-157	2304 088 053-157
D2	O-Ring	HNBR	2304 053 053-050	2304 053 053-157	2304 053 053-157	2304 069 053-157	2304 088 053-157	2304 113 053-157
D3	Seal	HNBR	5622 050 010-050	5622 050 010-050	5622 050 010-050	5622 065 010-050	5622 080 010-050	5622 100 010-050
D4	O-Ring	HNBR	2304 069 026-050	2304 069 026-150	2304 069 026-050	2304 082 026-050	2304 098 035-050	2304 118 045-050
D5	O-Rings (2x)	HNBR	2304 019 035-171	2304 019 035-171	2304 019 035-171	2304 019 035-171	2304 019 035-171	2304 019 035-171



Declaration of incorporation

Translation of the original

Manufacturer / authorised representative:

KIESELMANN GmbH
Paul-Kieselmann-Str. 4-10
75438 Knittlingen
Germany

Authorised representative,
for compiling technical documents:

Achim Kauselmann
KIESELMANN GmbH
Paul-Kieselmann-Str. 4-10
75438 Knittlingen
Germany

Product name

pneum. Lift actuators
pneum. Rotary actuators
Ballvalves
Butterfly valves
Single seat valves
Flow control valves
Throttle valve
Overflow valve
Double seat valve
Bellow valves
Sampling valves
Two way valves
Tankdome fitting

Function

Stroke movement
Rotary movement
Media cutoff
Media cutoff
Media cutoff
Control of liquified media
Control of liquified media
Definition of fluid pressure
Media separation
Sampling of liquids
Sampling of liquids
Media cutoff
Prevention of overpressure and vacuum

The manufacturer hereby states that the above product is considered as an incomplete machine in the sense defined in the Directive 2006/42/EC on Machinery. The above product is exclusively intended to be installed into a machine or an incomplete machine. The said product does not yet conform to all the relevant requirements defined in the Directive on Machinery referred to above for this reason.

The specific technical documents listed in Appendix VII, Part B, have been prepared. The Authorized Agent empowered to compile technical documents may submit the relevant documents if such a request has been properly justified.

Commissioning of an incomplete machine may only be carried out if it has been determined that the respective machine into which the incomplete machine is to be installed conforms to the regulations set out in the Directive on Machinery referred to above.

The above product conforms to the requirements of the directives and harmonized standards specified below:

- DIN EN ISO 12100-1 Safety of machinery
- DIN EN ISO 12100-2 Safety of machinery

Knittlingen, 18. 04. 2011

Klaus Dohle
General Director